

**Coffee System**  
**TANGO ACENTSELF, 1 group full-**  
**automatic machine with Cappuccinatore**

ITEM # \_\_\_\_\_

MODEL # \_\_\_\_\_

NAME # \_\_\_\_\_

SIS # \_\_\_\_\_

AIA # \_\_\_\_\_

**602562**  
**(TANGOACENTSELFCLC)**

Full-automatic machine, 1 group, 220x40 ml espresso cup/hr, 6,5 liter steam/coffee boiler, 1x1,7 kg coffee hopper for beans, 0,8-1,5 kg hopper for powder, Tango Cappuccinatore device with double function L: for hot milk and C: for foam by air injection

### Short Form Specification

#### Item No.

The super automatic multi-products Tango® ACE MT takes advantage of the reliability, usability and exceptional extraction quality that has established the reputation of the TANGO® range, and the ability to work with powdered products such as cocoa.

In its Self version, the Tango® ACE comes with lockers for beans and powder products hoppers and waste coffee drawer, it has no steam outlet neither ground coffee box for security reason. The Tango® ACE MT Self version is ideal for using in all self-service areas with its self-explanatory 7" color touch screen user interface easy to use.

With the addition of the Cappuccinatore device, the Tango® ACE MT Self offers the choice of fresh milk-based beverages as hot chocolate at the push of a button.

#### Delivery Capacity:

Espresso 40ml: 220 cups/h

Lungo 100ml: 150 cups/h

Hot chocolate 250ml: 110 cups/h

Cappuccino 100ml: 170 cups/h

Latte 100ml: 150 cups/h

Latte macchiato 300ml: 80 cups/h

Hot Water: 30 L/h

### Main Features

- 1 group full-automatic multi-products machine with self service configuration
- 6.5 liter steam/coffee boiler.
- Programmable hot water.
- Tango Cappuccinatore device with double feature L: for hot milk and C: for foam by air injection.
- Tango® ACE comes with lockers for beans and powder products hoppers and waste coffee drawer, it has no steam outlet neither ground coffee box for security reason.
- The super automatic multi-products Tango® ACE MT takes advantage of the reliability, usability and exceptional extraction quality that has established the reputation of the TANGO® range, and the ability to work with powdered products such as cocoa.
- The Tango® ACE MT Self version is ideal for using in all self-service areas with its self-explanatory 7" color touch screen user interface easy to use.
- With the addition of the Cappuccinatore device, the Tango® ACE MT Self offers the choice of fresh milk-based beverages as hot chocolate at the push of a button.
- Delivery Capacity:  
 Espresso 40ml: 220 cups/h  
 Lungo 100ml: 150 cups/h  
 Hot chocolate 250ml: 110 cups/h  
 Cappuccino 100ml: 170 cups/h  
 Latte 100ml: 150 cups/h  
 Latte macchiato 300ml: 80 cups/h  
 Hot Water: 30 L/h

### Construction

- 1 x 1,7 kg coffee hopper & coffee grinder + (0,8 at 1,5) kg hopper for powder.
- LCD Touchscreen.
- PID (proportional-integral-derivative) Temperature control: a precise controller algorithm system that gives consistency and accuracy to brewing temperature management system.
- Safety locks.

### Optional Accessories

- Side milk refrigerator 8 liter nominal capacity for up to 4 liter milk containers PNC 871014
- Side milk refrigerator 8 liter nominal capacity for up to 4 liter milk containers with digital display PNC 871015

APPROVAL: \_\_\_\_\_

Front

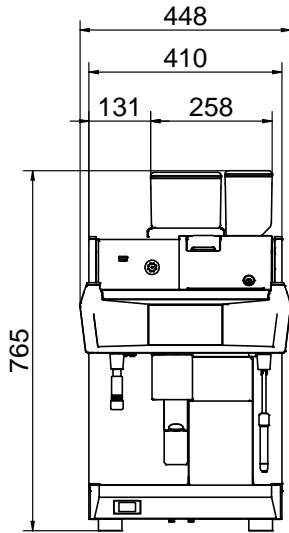

Side

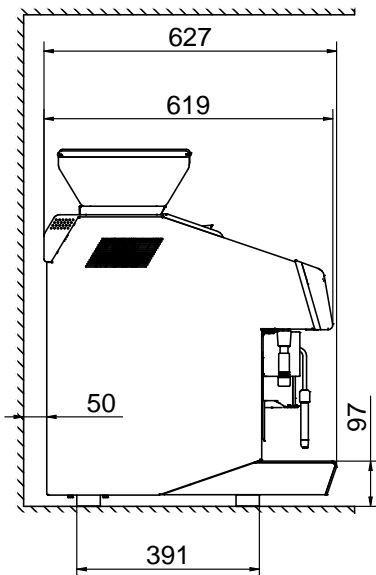

Top

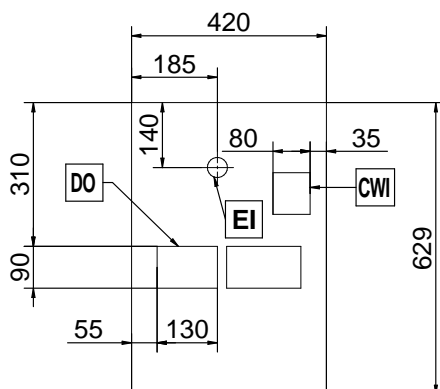

### Electric

**Supply voltage:**

602562 (TANGOACEMTSELFCLC) 400 V/3N ph/50 Hz

**Electrical power max.:** 5.2 kW

**Plug type:** Cable without plug

### Water:

**Cold water temperature (min/max):** 5 / 60 °C

### Key Information:

**External dimensions, Width:** 448 mm

**External dimensions, Depth:** 627 mm

**External dimensions, Height:** 846 mm

**Net weight:** 91 kg

**Shipping volume:** 0.69 m<sup>3</sup>

### Sustainability

**Current consumption:** 7.5 Amps